

POWERTRUCK

POWERED STAIRWAY HAND TRUCK

PRODUCT
INFORMATION

THIS ELECTRIC/BATTERY POWERED HAND TRUCK ALLOWS FOR EASY AND SAFE STAIR ASCENT & DESCENT



For use in goods transport to safely and easily move heavy goods up and down a flight of stairs. Can also be used in emergency situations and power outages.

MAIN FEATURES

Rechargeable lithium ion battery pack

Fully charged in 1.5 hours (Equivalent to going up and down a 5 story building flight of stairs 30 times)

High strength aluminum frame

Increased strength and robustness for continued use

Lockable rear wheels

For situations where the truck needs to remain stationary

Ergonomic adjustable handle

For ease of deployment and compact storage

Easy to use control panel

Control panel with on/off power and ascent and descent buttons

Additional operator handles

Adds stability when using additional operators during transportation

Adjustable stair track

Tension control system for perfect transportation with tool included

POWERTRUCK

POWERED STAIRWAY HAND TRUCK

TECHNICAL
SPECIFICATION

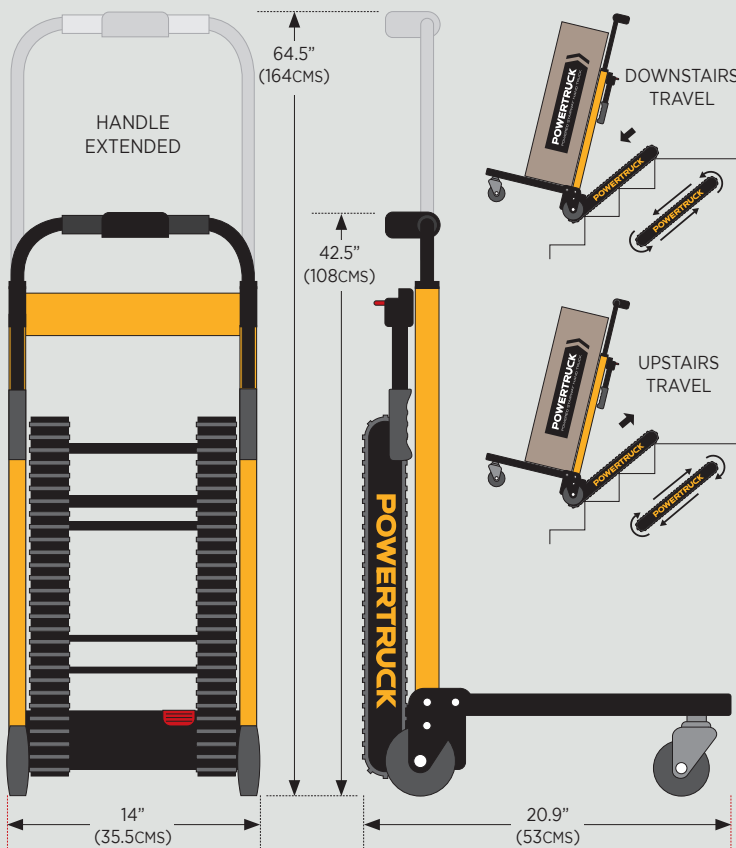

Warranty:	Lifetime
Structure:	Platform
Material:	Metal
Wheel:	Four-wheel
Battery:	24V/13.2Ah Li-ion
Motor:	DC24v/120-200W
Gross weight:	110lbs (50kg)
Capacity:	440lbs (200kg)
Handle height:	Upto 64.5" (164cms)

Includes

- Battery Charger (US/EU/UK)
- Rechargeable Battery
- Load Securing Strap
- Manufacturers Warranty
- 2 Keys
- User Guide
- Wall Hooks
- Dust Cover

Benefits

- FDA Registered
- CE & ISO 9001 Certificated
- Robust and compact in size
- Provides a quick, easy and safe transportation of heavy goods
- Easy to use
- One person operation
- No heavy lifting required
- Enables small attendants to easily move goods three times their weight
- Easy to open, ready to use in seconds
- Folds for compact storage
- Flame retardant materials
- Wipeable materials and anti-microbial paint.
- Exceeds fire safety requirements